



Company name:

Created by:

Phone:

Date:

13/07/2024

97844677 CR 10-10 A-A-A-E-HQBE 50 Hz

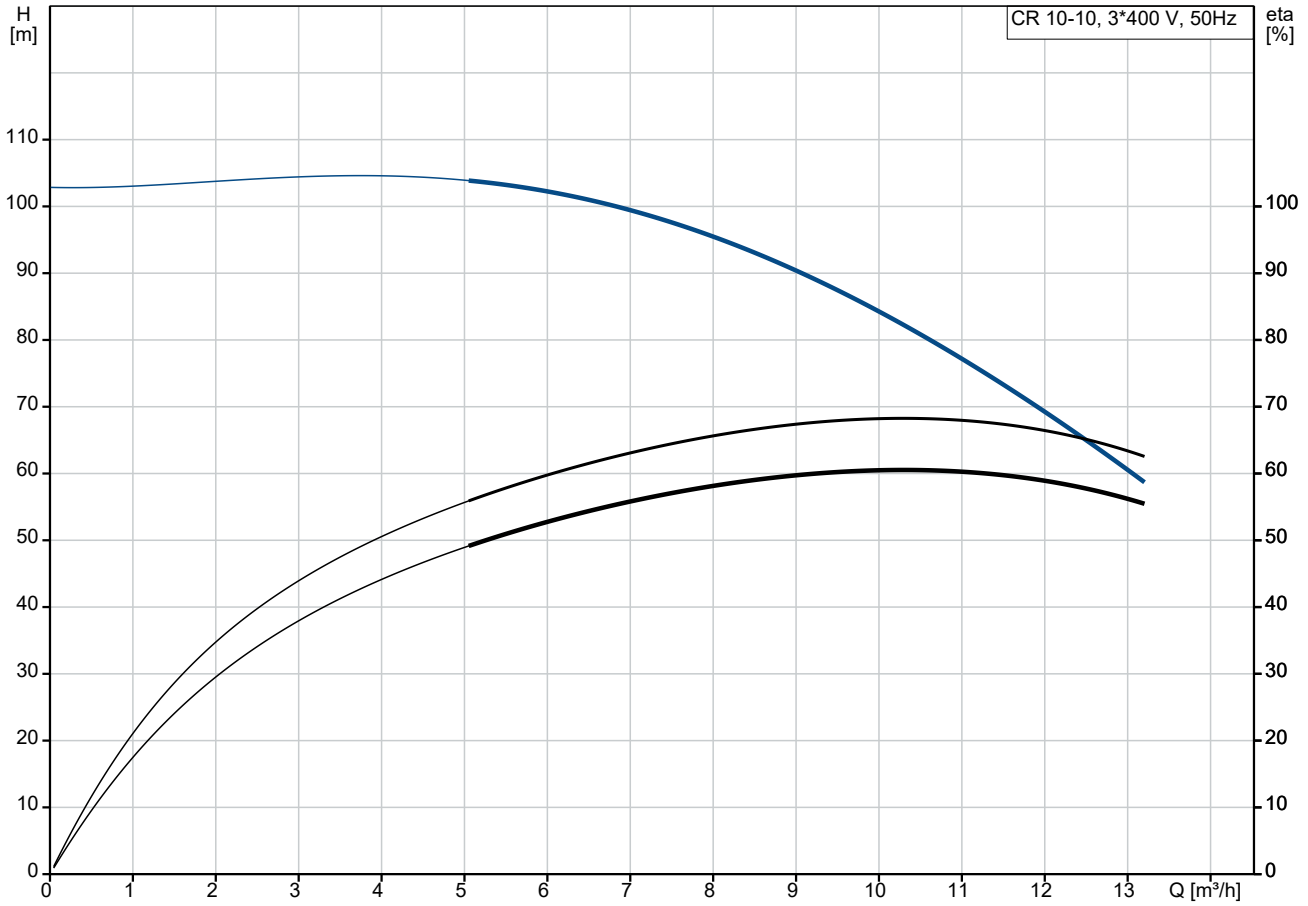

Pumped liquid = Water
Liquid temperature during operation = 20 °C
Density = 998.2 kg/m³

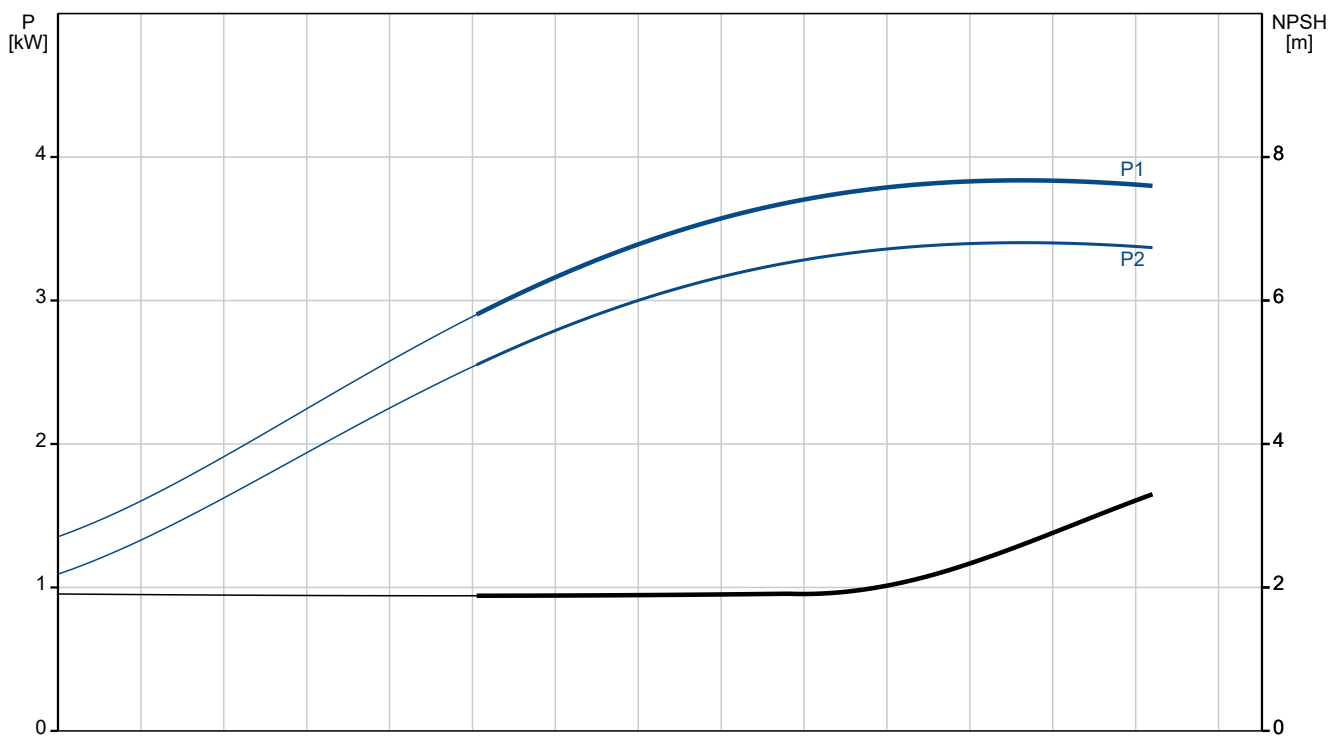

Description	Value
General information:	
Product name:	CR 10-10 A-A-A-E-HQBE
Product No:	97844677
EAN number:	5710625686118
Technical:	
Pump speed on which pump data are based:	2917 rpm
Rated flow:	10 m ³ /h
Rated head:	81.6 m
Maximum head:	102 m
Stages:	10
Impellers:	10
Number of reduced-diameter impellers:	0
Low NPSH:	N
Pump orientation:	Vertical
Shaft seal arrangement:	Single
Code for shaft seal:	HQBE
Approvals:	CE,EAC,UKCA,SEPRO
Approvals for drinking water:	WRAS
Curve tolerance:	ISO9906:2012 3B
Pump version:	A
Model:	A
Materials:	
Base:	Cast iron
Base:	EN 1561 EN-GJL-200
Base:	ASTM A48-25B
Impeller:	Stainless steel
Impeller:	EN 1.4301
Impeller:	AISI 304
Material code:	A
Code for rubber:	E
Bearing:	SIC
Installation:	
Maximum ambient temperature:	60 °C
Maximum operating pressure:	16 bar
Max pressure at stated temp:	16 bar / 120 °C
Max pressure at stated temp:	16 bar / 0 °C
Type of connection:	Oval / Rp
Size of inlet connection:	1 1/2 inch
Size of outlet connection:	1 1/2 inch
Pressure rating for connection:	PN 16
Flange size for motor:	FT130
Connect code:	A
Liquid:	
Pumped liquid:	Water
Liquid temperature range:	0 .. 120 °C
Selected liquid temperature:	20 °C
Density:	998.2 kg/m ³
Electrical data:	
Motor standard:	IEC
Motor type:	112MC
Rated power - P2:	4 kW
Power (P2) required by pump:	4 kW
Mains frequency:	50 Hz
Rated voltage:	3 x 380-415D V
Rated current:	7.9 A
Starting current:	1000-1110 %

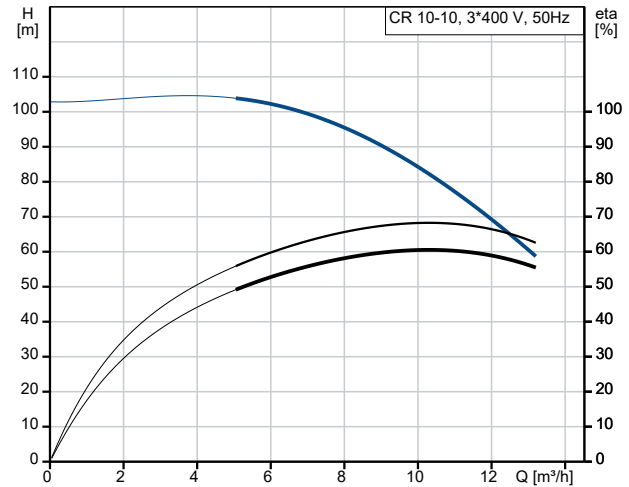

Pumped liquid = Water
Liquid temperature during operation = 20 °C
Density = 998.2 kg/m³

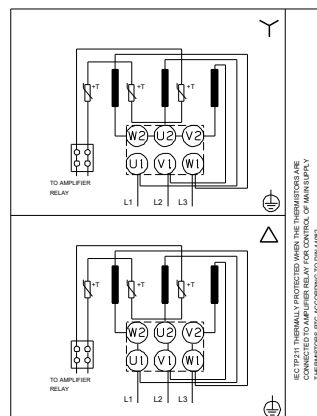
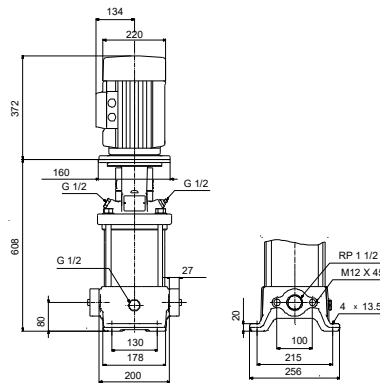
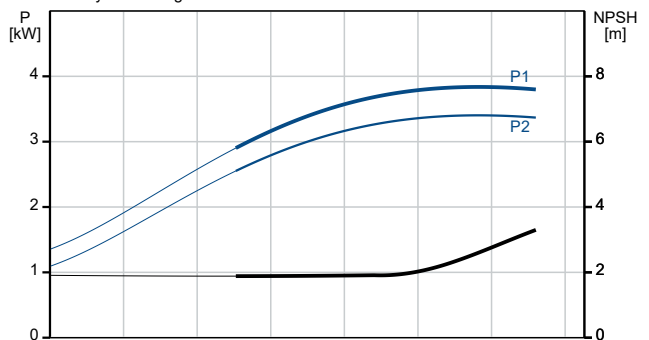



Company name:

Created by:

Phone:

Date:

13/07/2024

Description	Value
Cos phi - power factor:	0.87
Rated speed:	2920-2940 rpm
IE Efficiency class:	IE3
Motor efficiency at full load:	88.1 %
Motor efficiency at 3/4 load:	88.6-88.2 %
Motor efficiency at 1/2 load:	85.2-88.1 %
Number of poles:	2
Enclosure class (IEC 34-5):	55 Dust/Jetting
Insulation class (IEC 85):	F
Built-in motor protection:	PTC
Motor No:	85U15413
Controls:	
Frequency converter:	None
Others:	
Terminal box position:	6
Minimum efficiency index, MEI ≥:	0.70
Net weight:	71 kg
Gross weight:	75 kg
Shipping volume:	0.13 m ³
Sales region:	United Arab Emirates

97844677 CR 10-10 A-A-A-E-HQBE 50 Hz

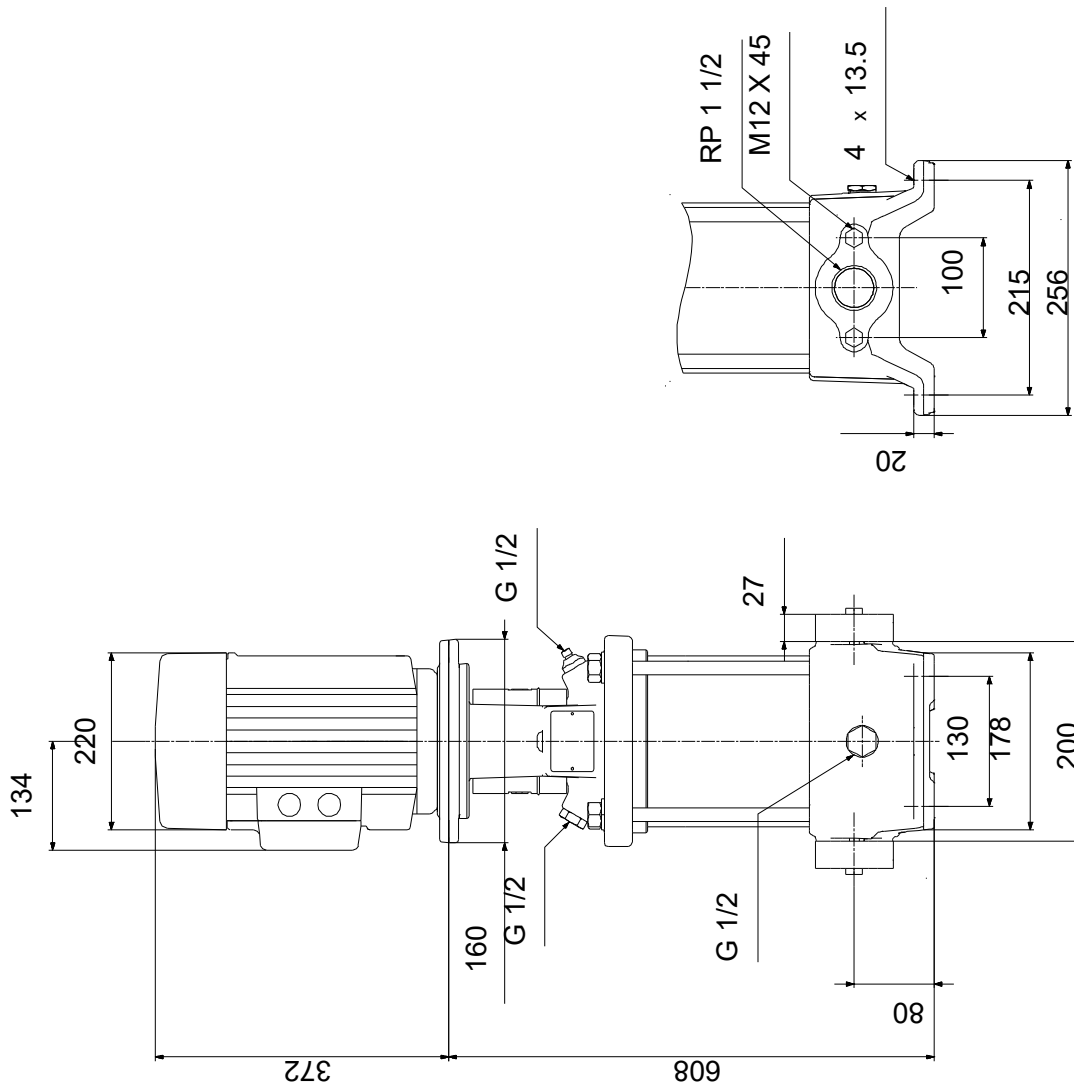

Note! All units are in [mm] unless others are stated.
Disclaimer: This simplified dimensional drawing does not show all details.